

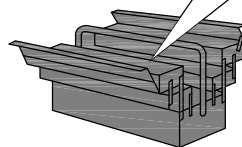

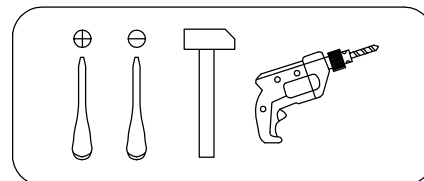

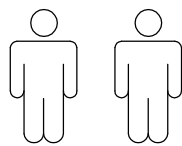

















- |   |                                     |
|---|-------------------------------------|
| <b>(D)</b> Montageanleitung             | <b>(GB)</b> Assembly instructions   |
| <b>(FR)</b> Notice de montage           | <b>(IT)</b> Istruzioni di montaggio |
| <b>(NL)</b> Handleiding voor de montage | <b>(PL)</b> Instrukcja montazu      |
| <b>(CZ)</b> Montážní návod              | <b>(SK)</b> Návod na montáž         |
| <b>(HU)</b> Szerelési útmutató          | <b>(RO)</b> Instrukțiuni de montaj  |
| <b>(TR)</b> Montaj talimati             | <b>(RU)</b> Инструкция по монтажу   |



0  
10  
20  
30  
40  
50  
60  
70  
80  
90  
100

<b>A</b> 090913 7x32  <b>x40</b>	<b>B</b> 000146 15x12  <b>x28</b>	<b>C</b> 000147 15x16  <b>x4</b>	<b>D</b> 090912 15x10  <b>x8</b>	<b>E</b> 000151 8x35  <b>x28</b>	<b>F</b> 100640 20x0.5  <b>x8</b>
<b>G</b> 101608 7x50  <b>x10</b>	<b>H</b> 168849 L350  <b>x2</b>	<b>I</b> 000767 3x13  <b>x8</b>	<b>J</b> 000762 3.5x13  <b>x8</b>	<b>K</b> 098889  <b>x8</b>	<b>L</b> 038912 4x30  <b>x8</b>
<b>M</b> 135021  <b>x10</b>	<b>N</b> 000759 3x20  <b>x14</b>	<b>O</b> 230041 22x16  <b>x7</b>	<b>P</b> 190830  <b>x2</b>	<b>Q</b> 013794 M4x22  <b>x4</b>	<b>R</b> 155999  <b>x1</b>
<b>S</b> 000754 3.5x16  <b>x2</b>	<b>T</b> 090185 4.5x45  <b>x1</b>	<b>U</b> 013859 8x40  <b>x1</b>			

N	Size/MaB (mm)	Qty	✓	N	Size/MaB (mm)	Qty	✓
1	480x60x22	1		11	533x167x16	1	
2	480x60x22	1		12	159x376x16	1	
3	480x60x22	1		13	1074x377x16	1	
4	480x60x22	1		14	1074x395x16	1	
5	350x118x12	2		15	1074x80x22	2	
6	350x118x12	2		16	1214x435x16	1	
7	480x118x12	2		17	1074x381x3	1	
8	398x378x16	1		18	490x347x3	2	
9	398x378x16	1		19	200x104x16	1	
10	533x167x16	1		20	200x104x16	1	

# Service - Dienstverlening - Serwis - Servis - Сервисная служба

Name - Naam - Nazwa - Isim - Название

Nr. - No. - Номер

Typ - Type - Тип - Тип

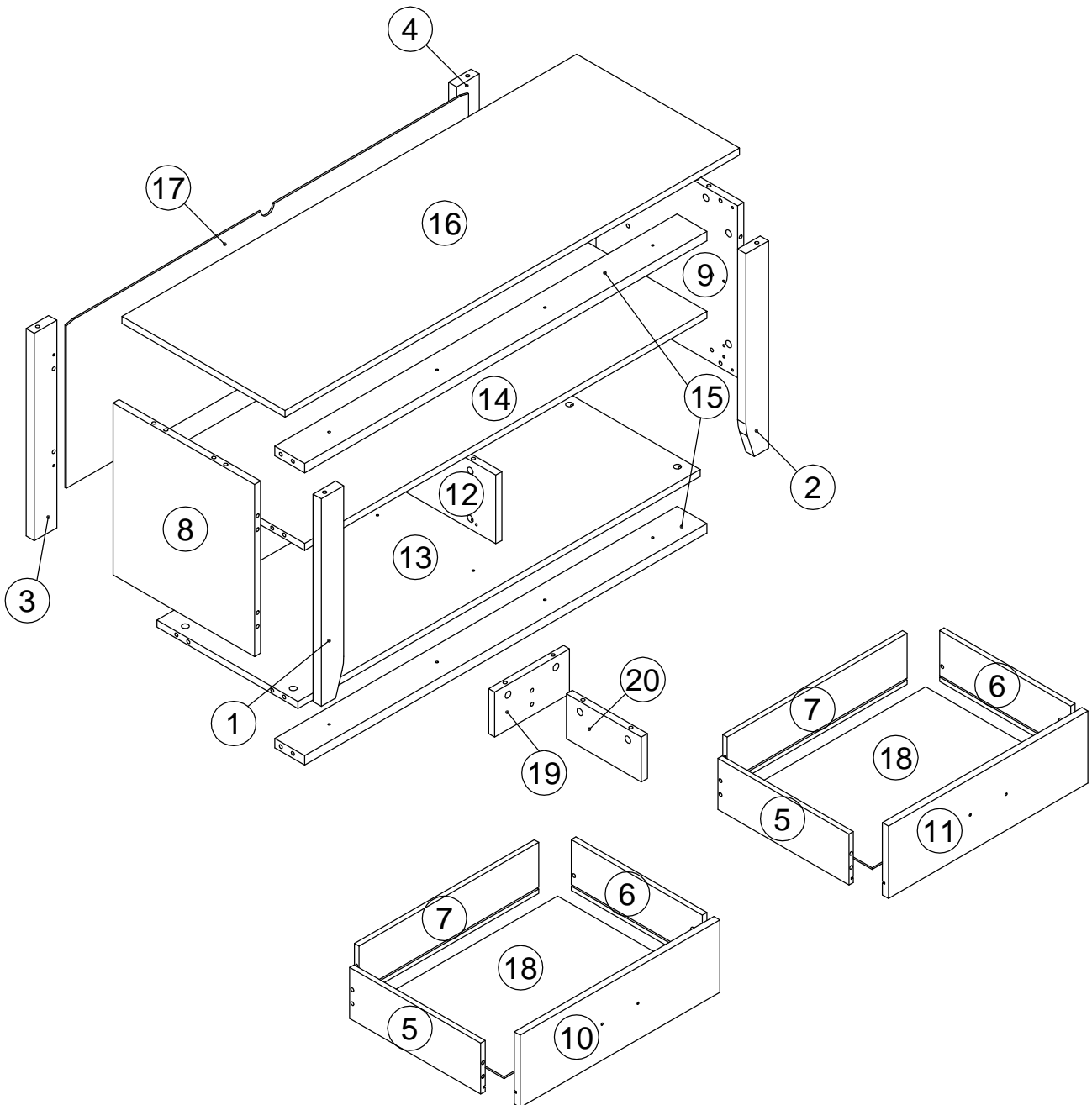
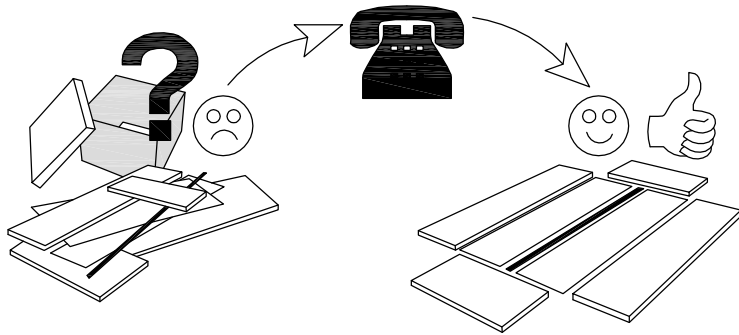
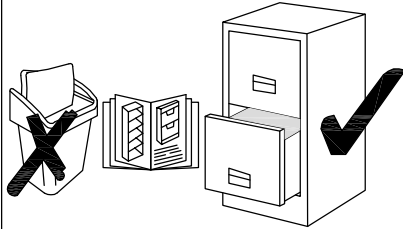

1

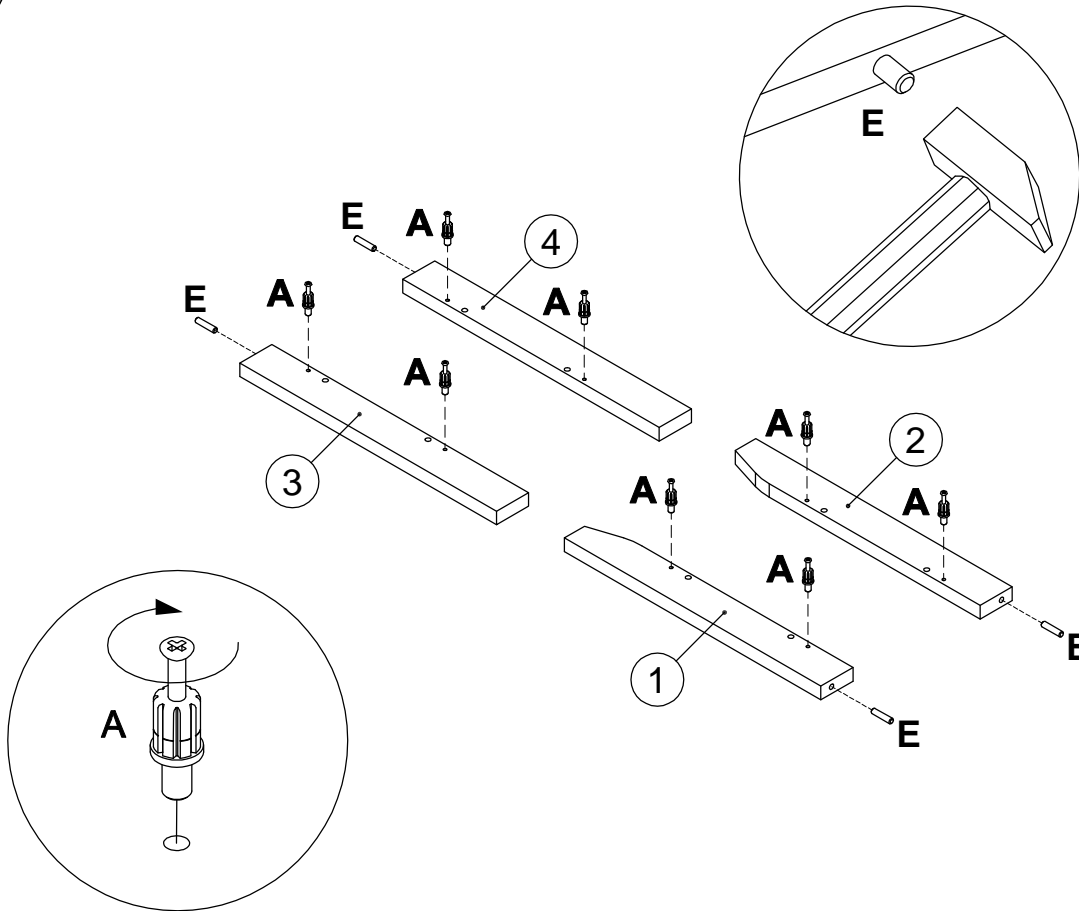

<b>A</b>		7x32
090913		<b>x8</b>
<b>E</b>		8x35
000151		<b>x4</b>

2

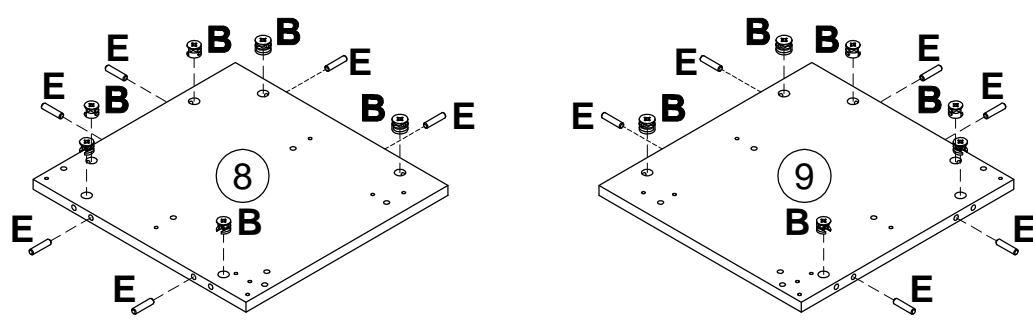

<b>B</b>		15x12
000146		<b>x12</b>
<b>E</b>		8x35
000151		<b>x12</b>

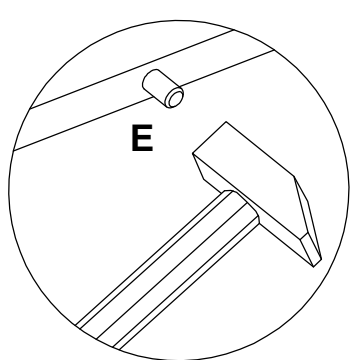
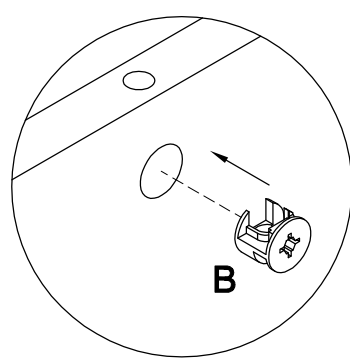

3

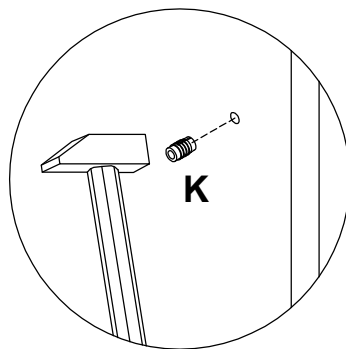
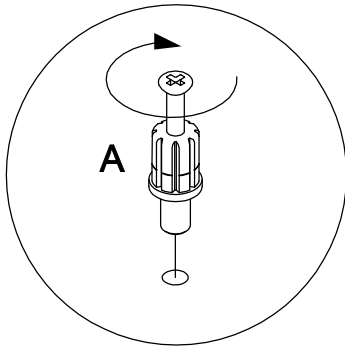
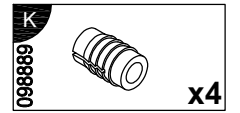
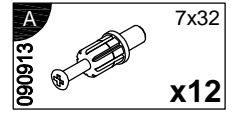
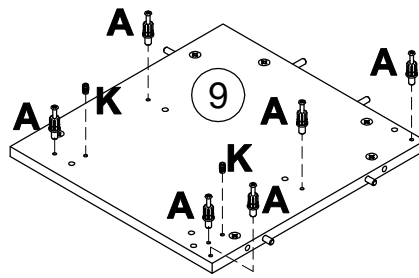
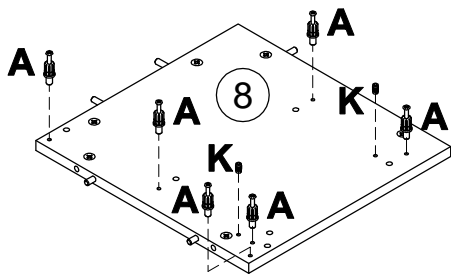

4

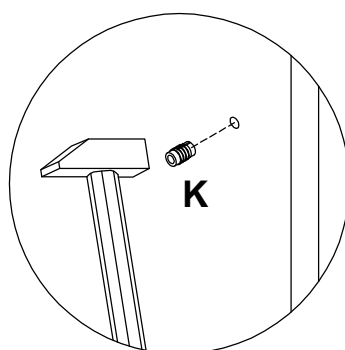
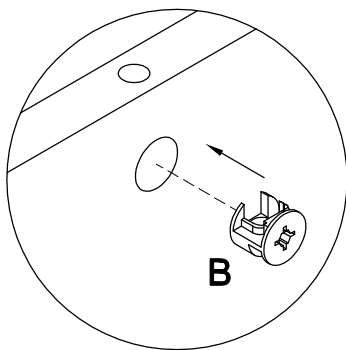
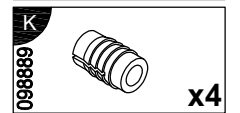
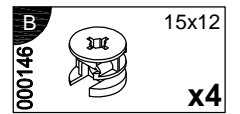
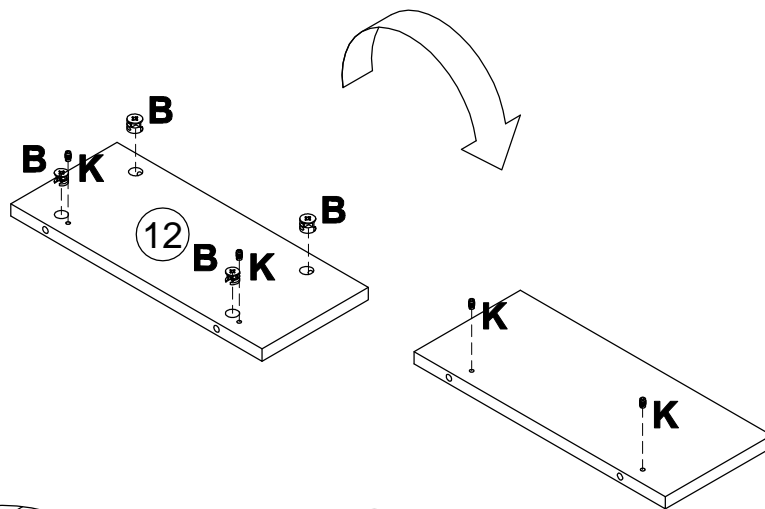

5

5

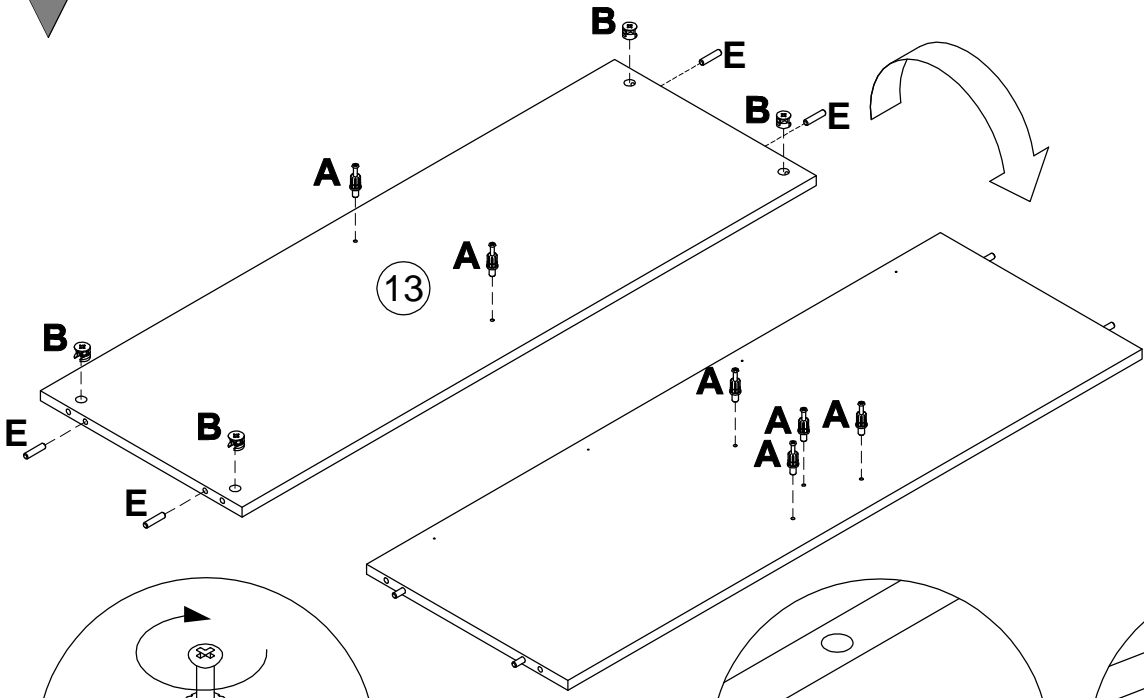

<b>A</b>		7x32
090913		<b>x6</b>
<b>B</b>		15x12
000146		<b>x4</b>
<b>E</b>		8x35
000151		<b>x4</b>

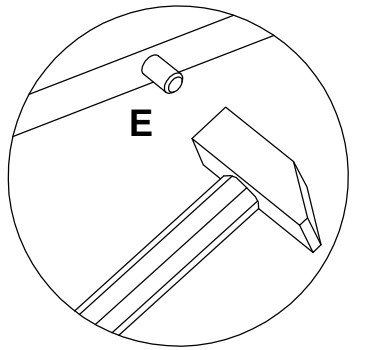
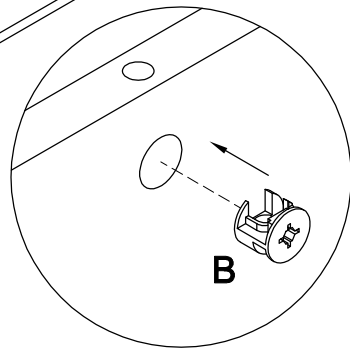
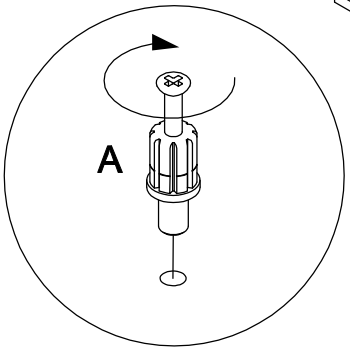

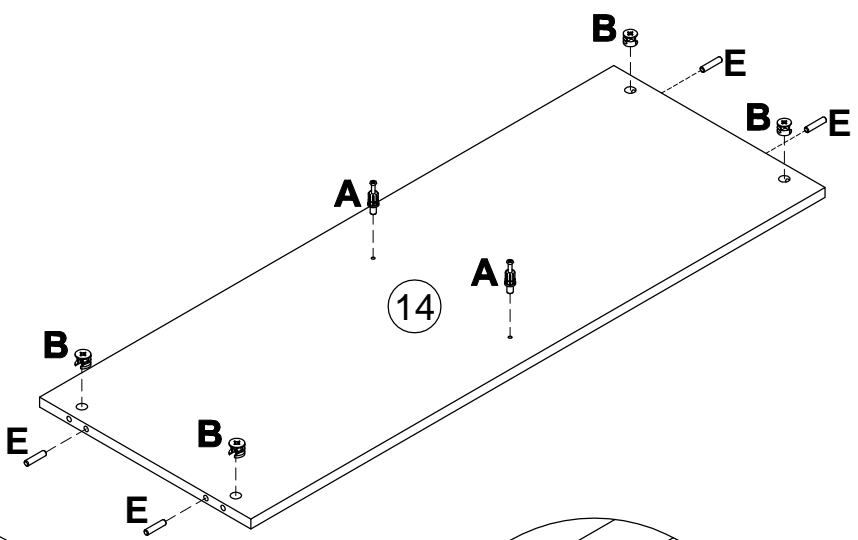

6

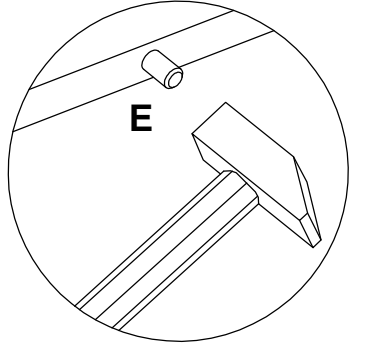
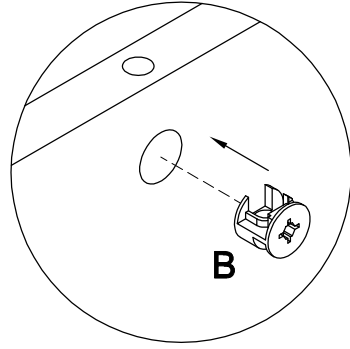
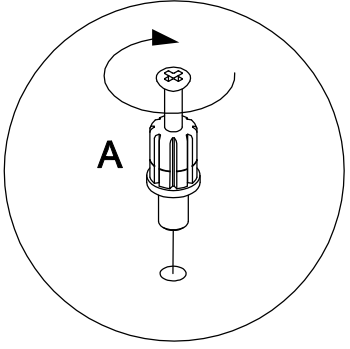

<b>A</b>		7x32
090913		<b>x2</b>
<b>B</b>		15x12
000146		<b>x4</b>
<b>E</b>		8x35
000151		<b>x4</b>



7  
x2

<b>C</b> 000147		15x16	<b>x4</b>
<b>E</b> 000151		8x35	<b>x4</b>

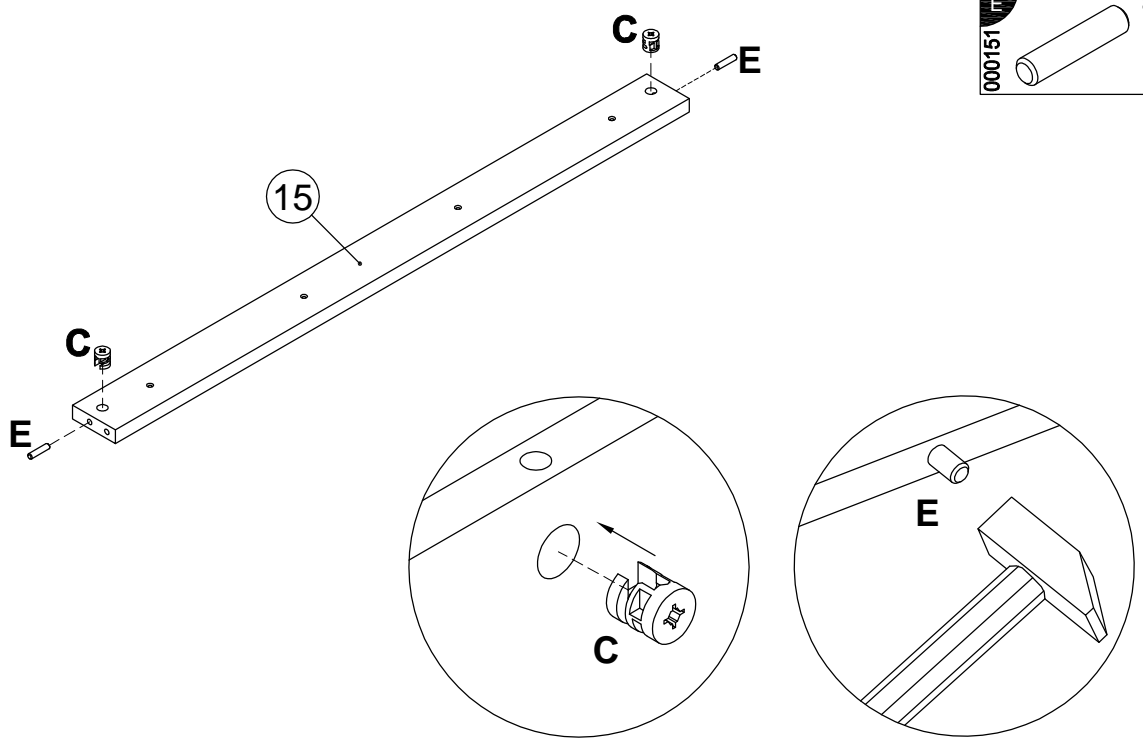

8

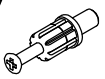
<b>A</b> 090913		7x32	<b>x4</b>
--------------------	---	------	-----------

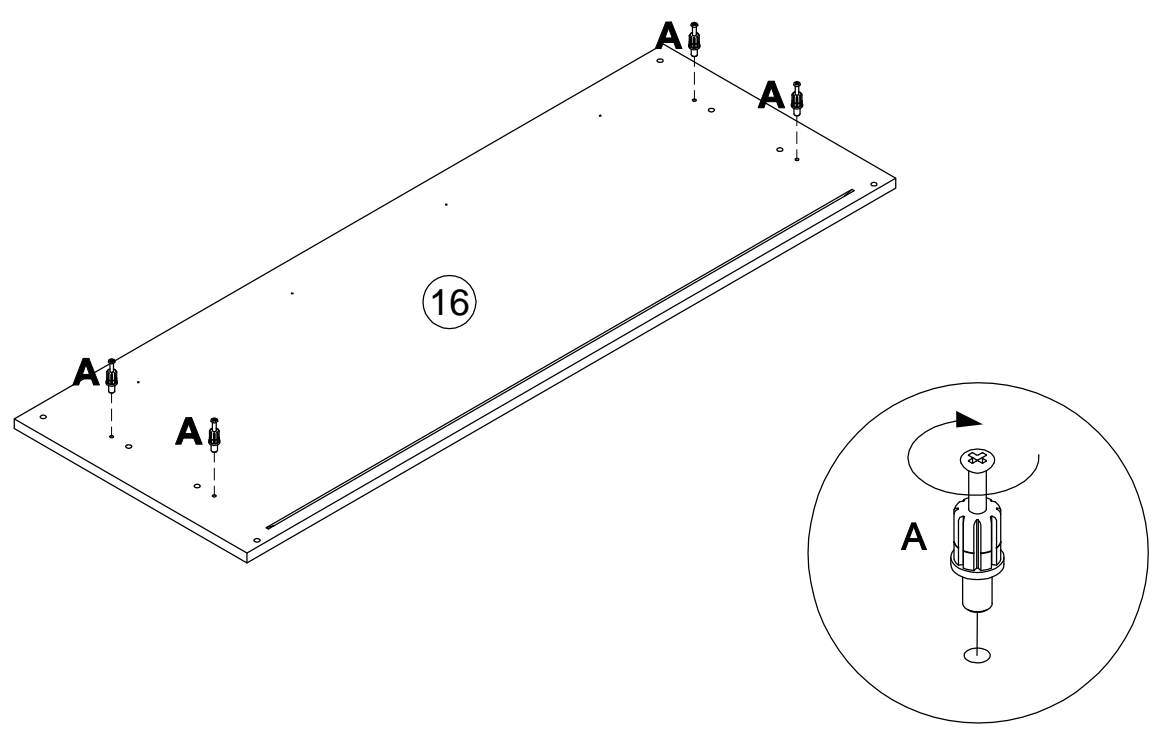

**B**  
1000146  15x12  
**x4**

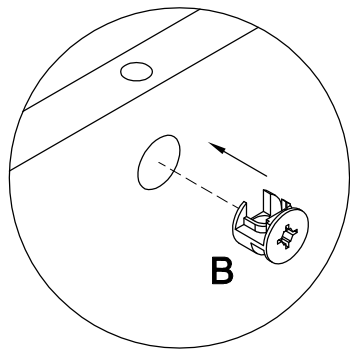
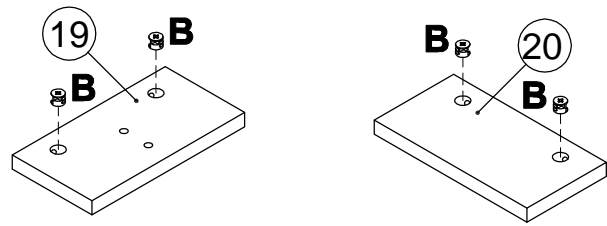

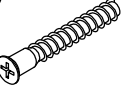
**G**  
101608  7x50  
**x2**

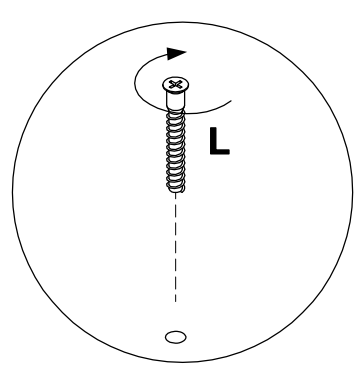
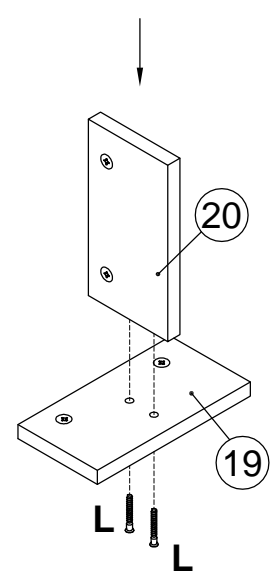
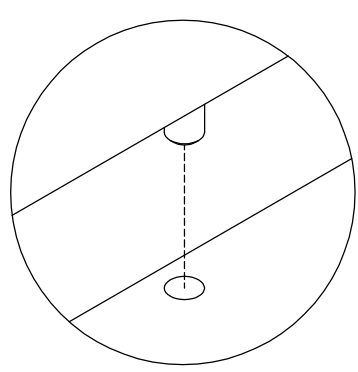



11

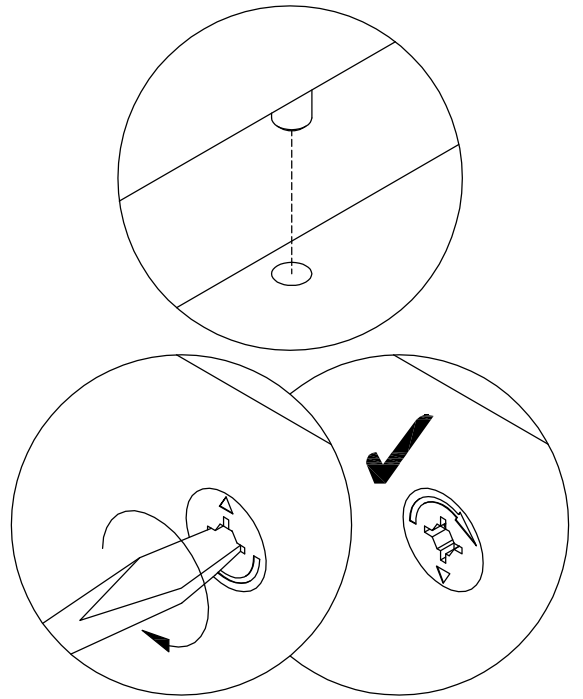
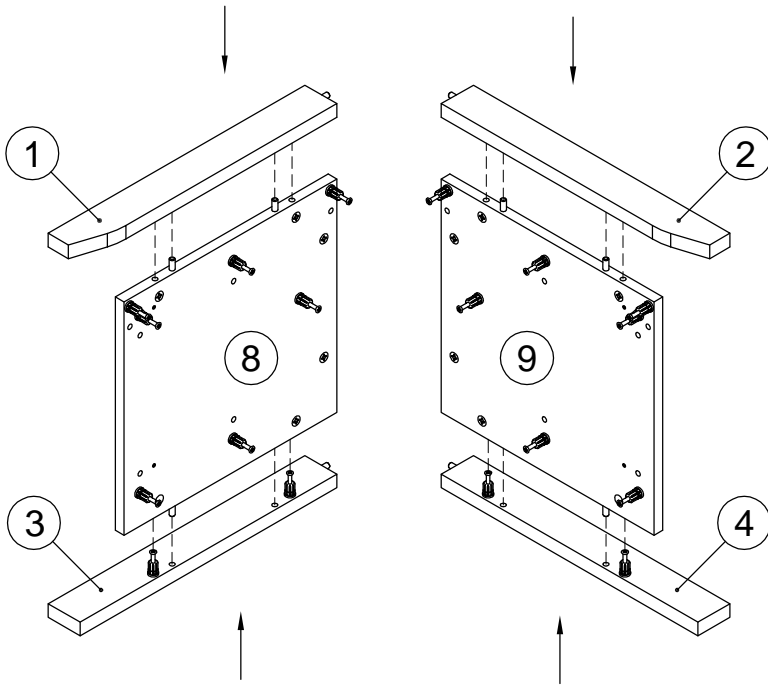

12

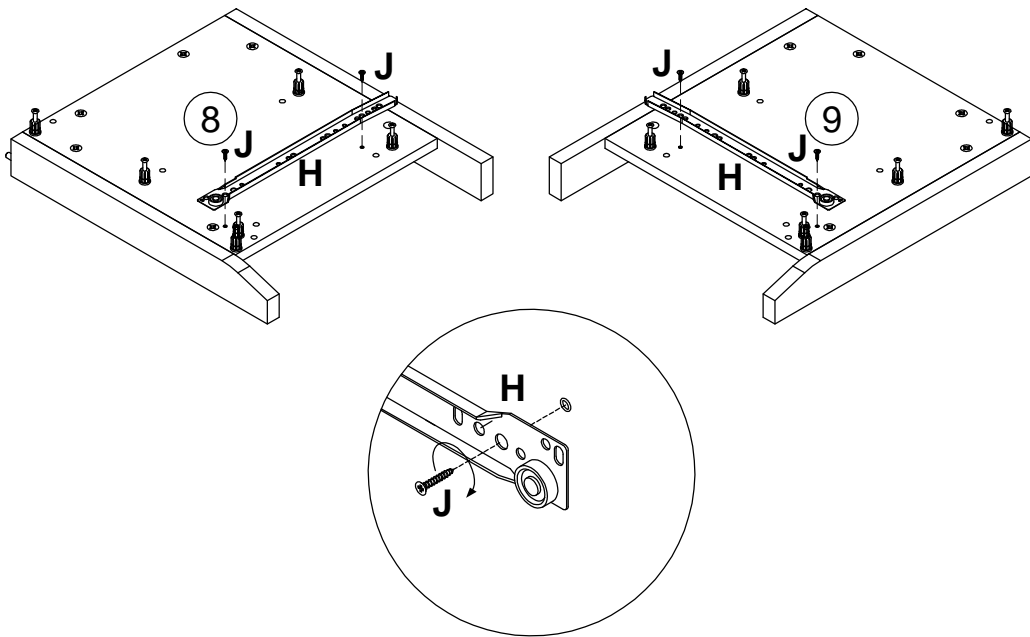

<b>H</b>		L350
168849		x1
<b>J</b>		3.5x13
000762		x4

13

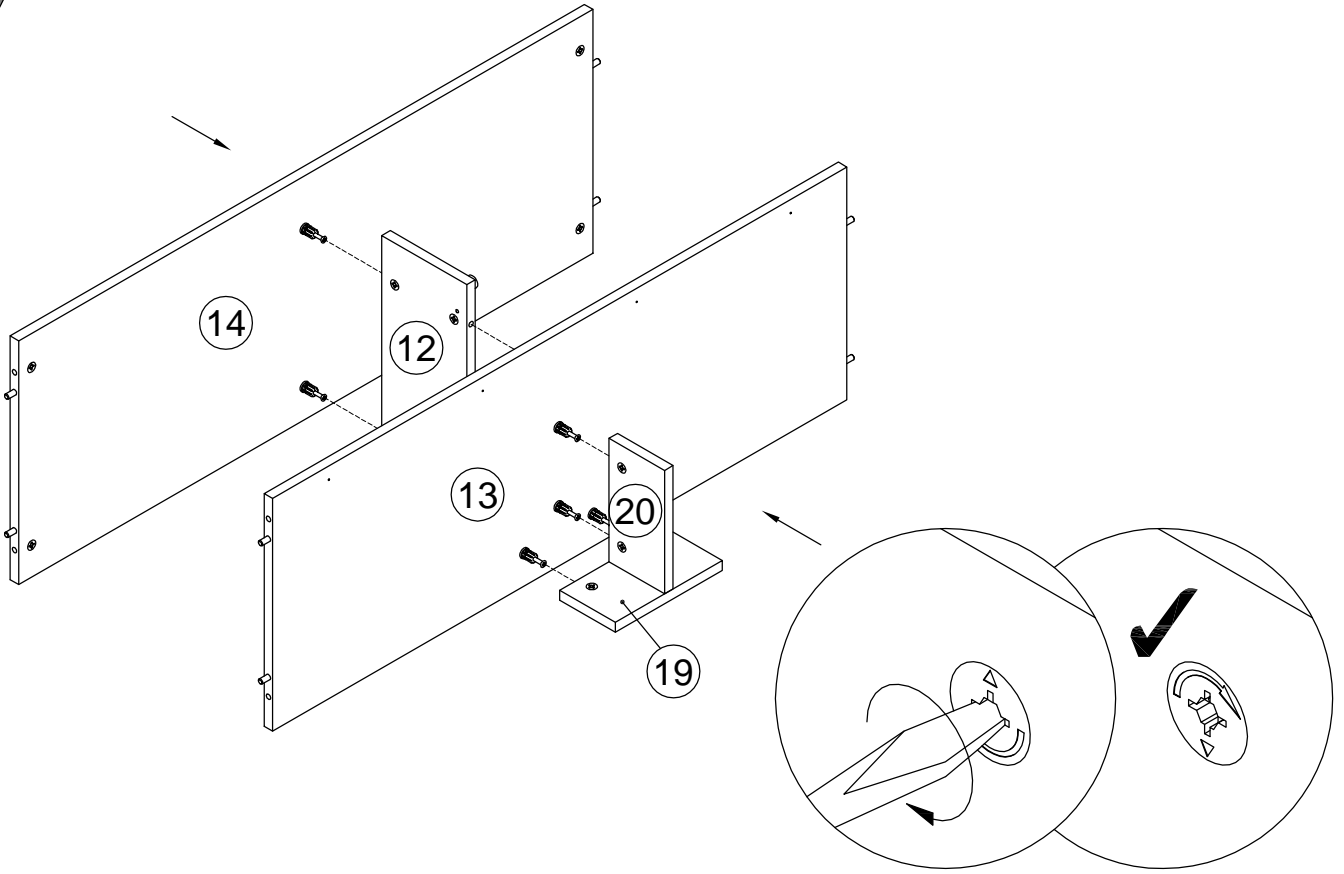

14

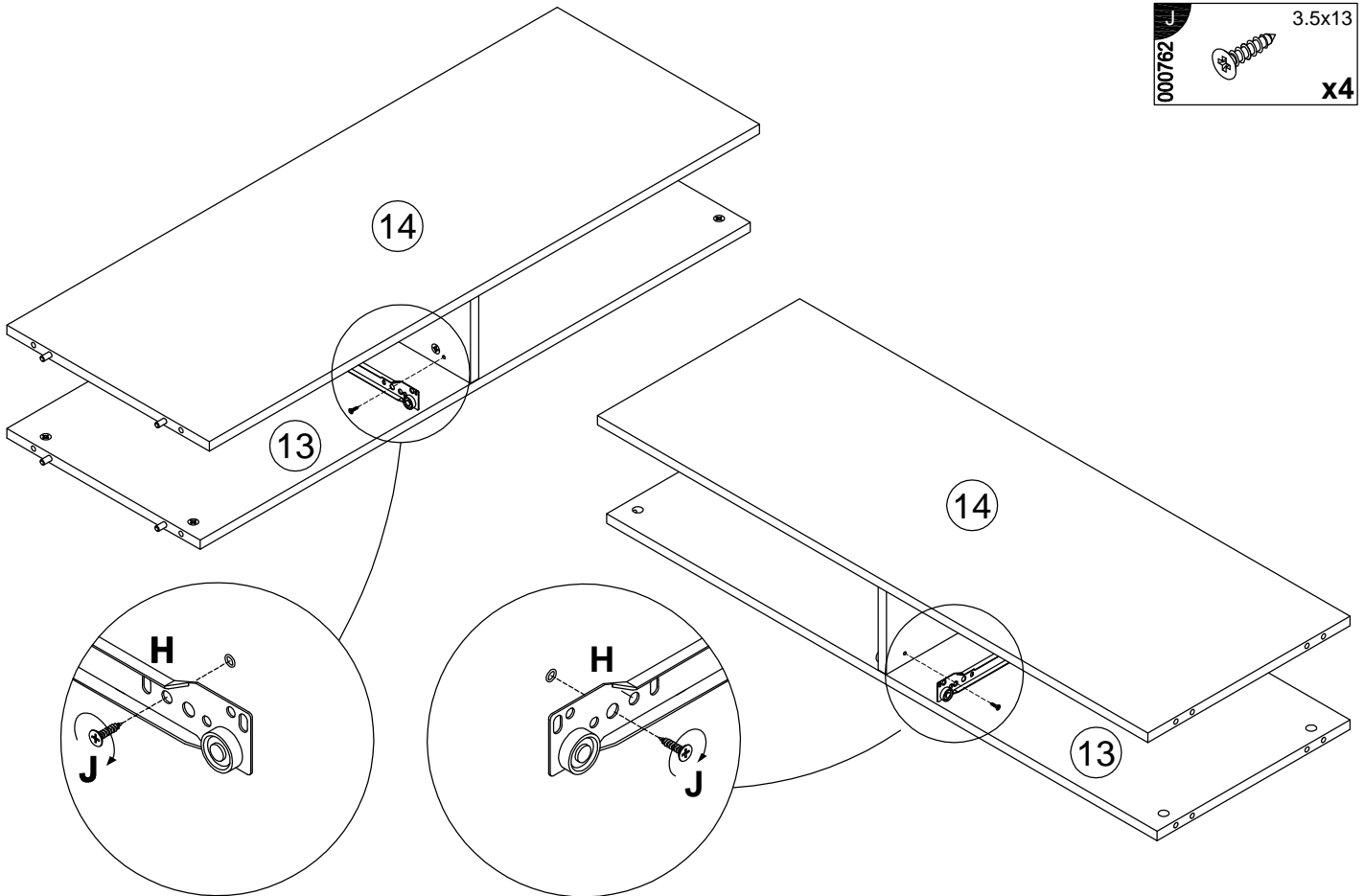

15

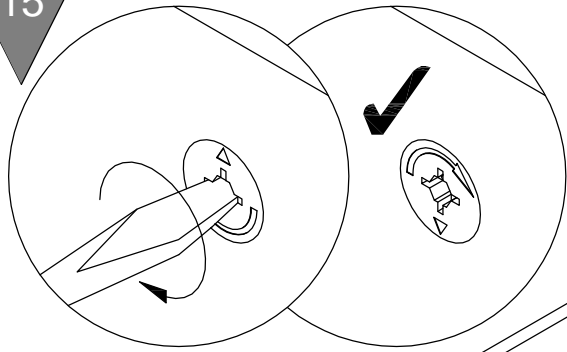

038912	L	4x30
		x4
230041	O	22x16
		x7

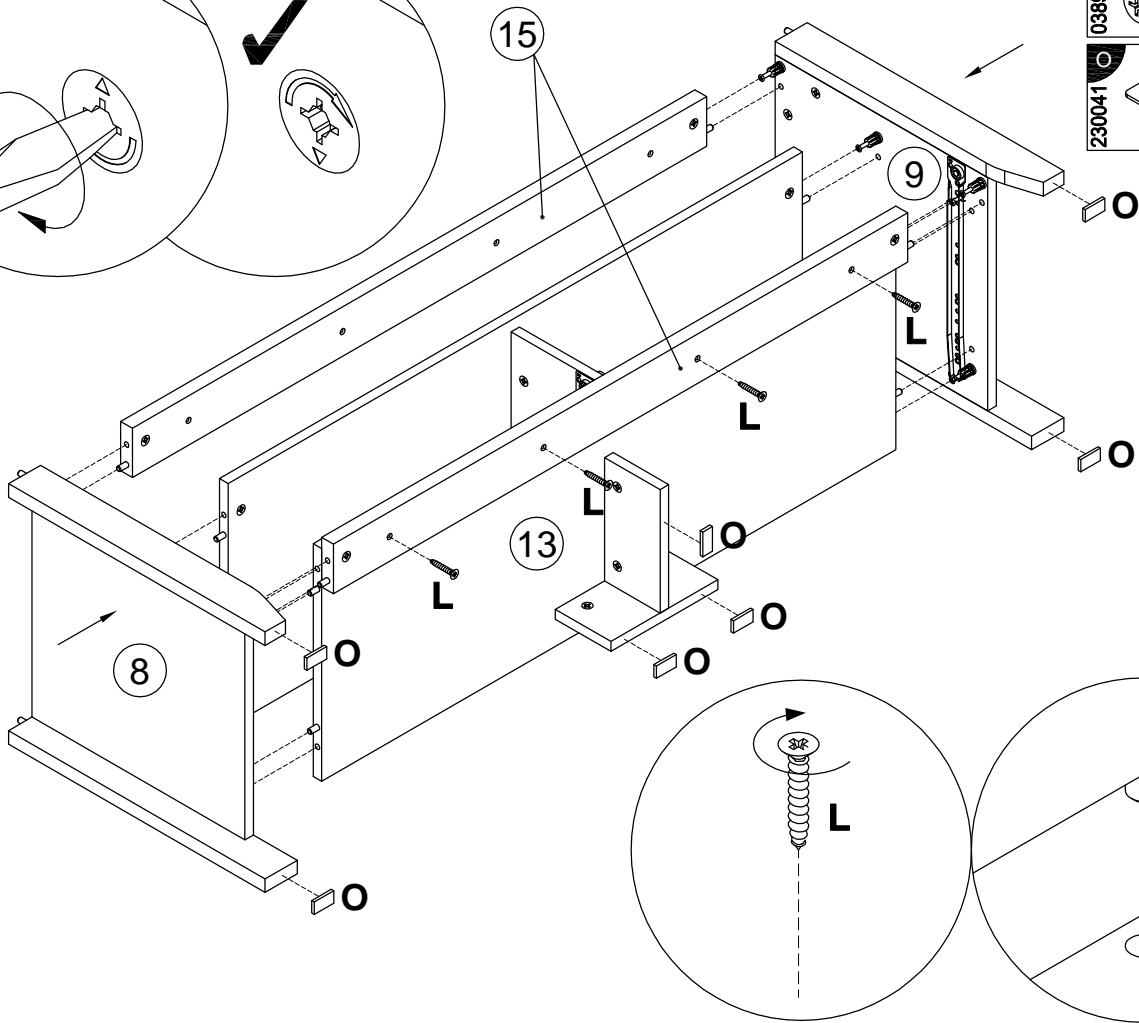

16

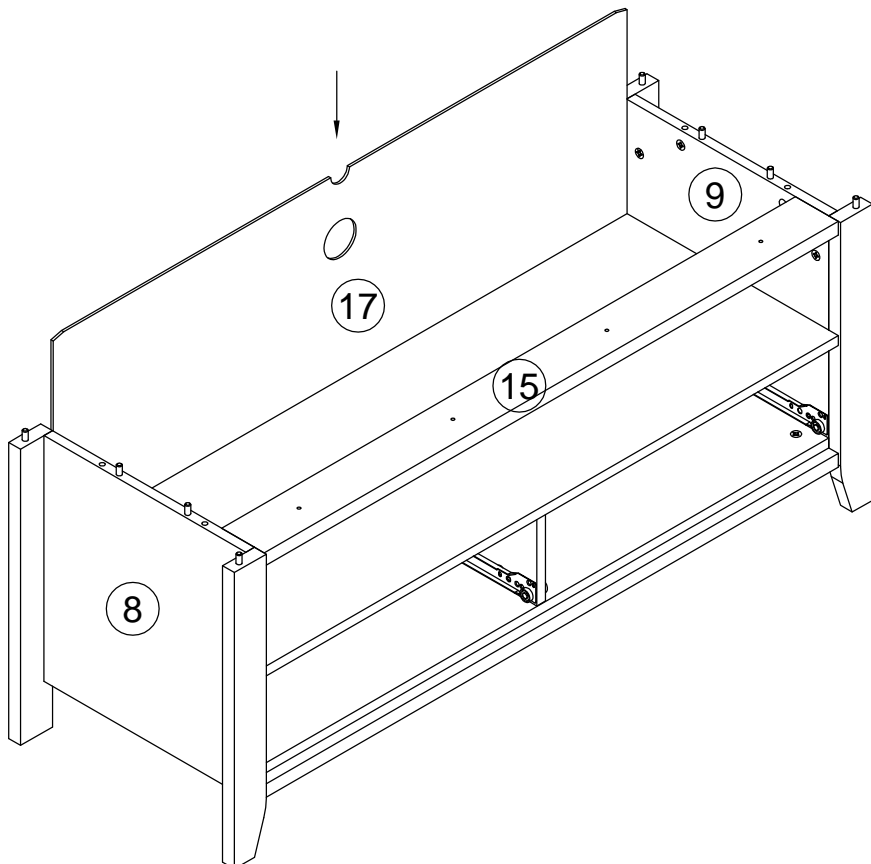

17

038912 L 4x30 x4

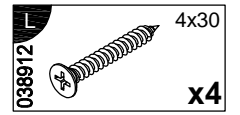

038912 L 4x30 x4

x4

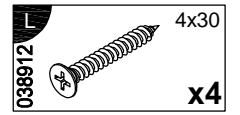

18

135021 M x10

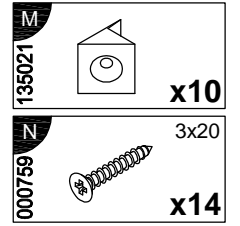

000759 N 3x20 x14

000759 N 3x20 x14

L1=L2

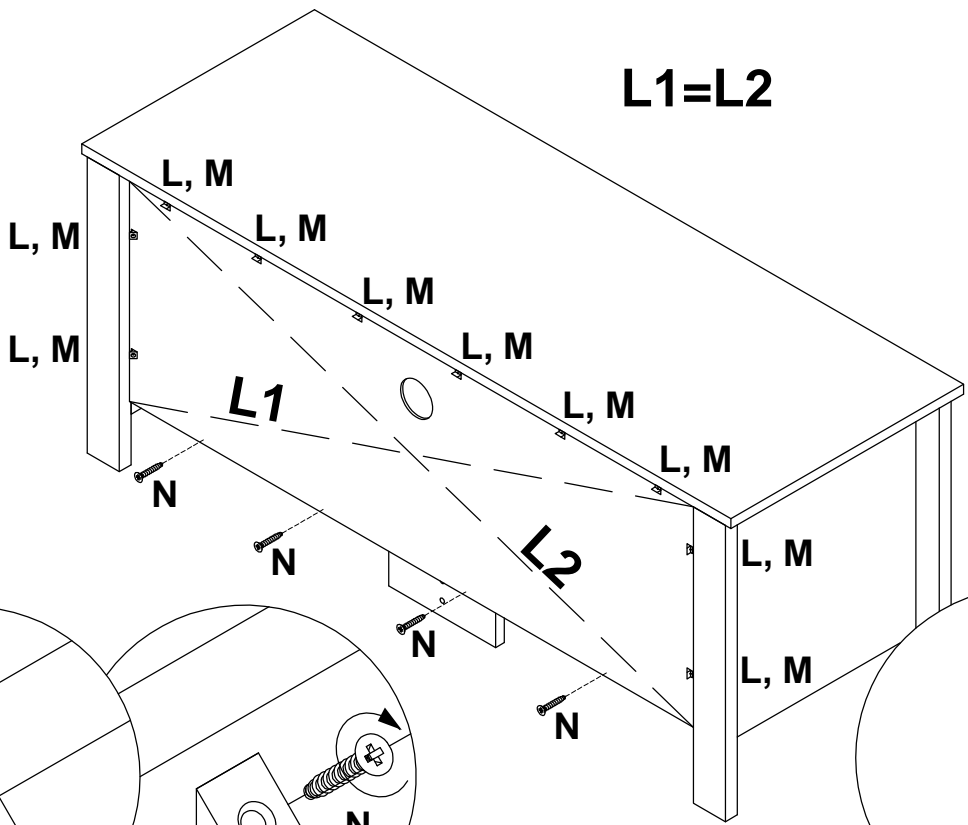

19

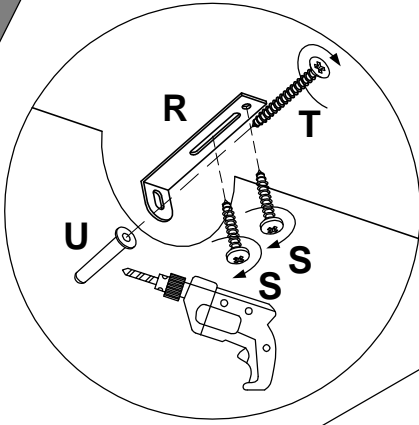

R, S, T, U

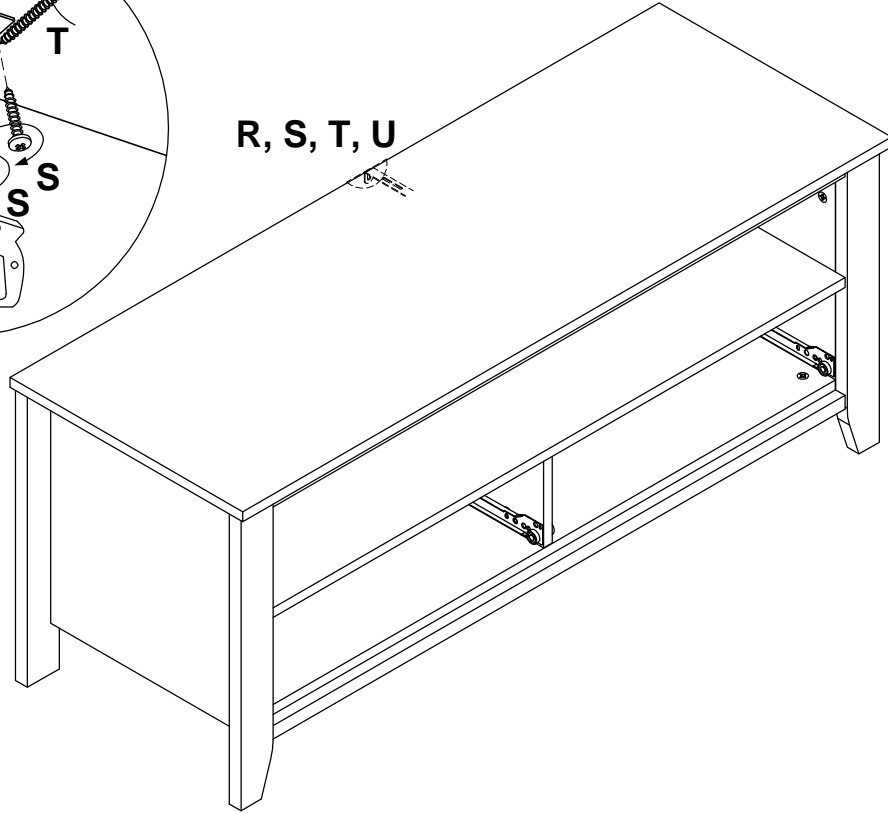

R		x1
S		x2
T		x1
U		x1

20

x2

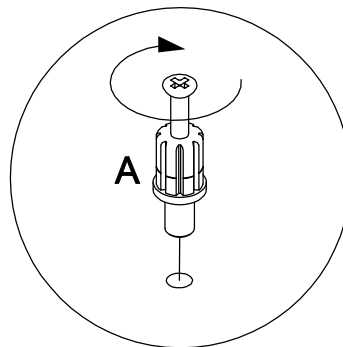
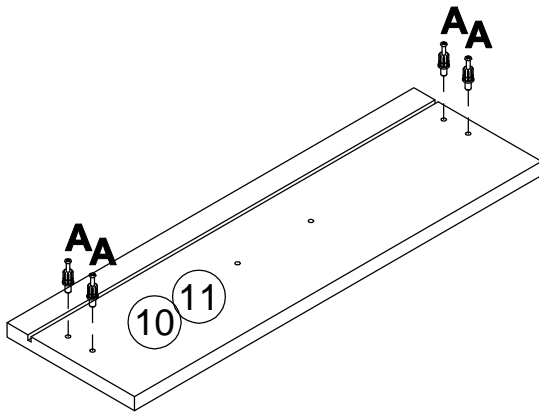
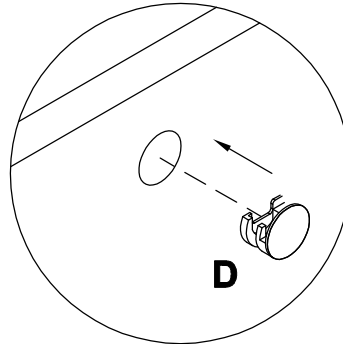
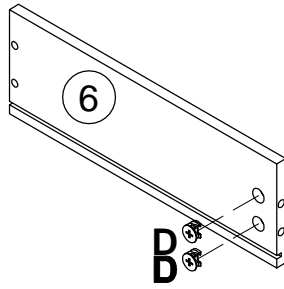
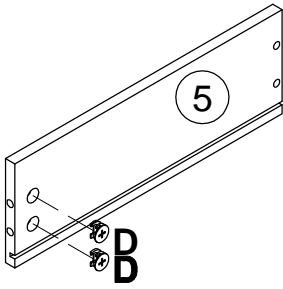

A		7x32
090913		x8
D		15x10
090912		x8
G		x8
101608		x8

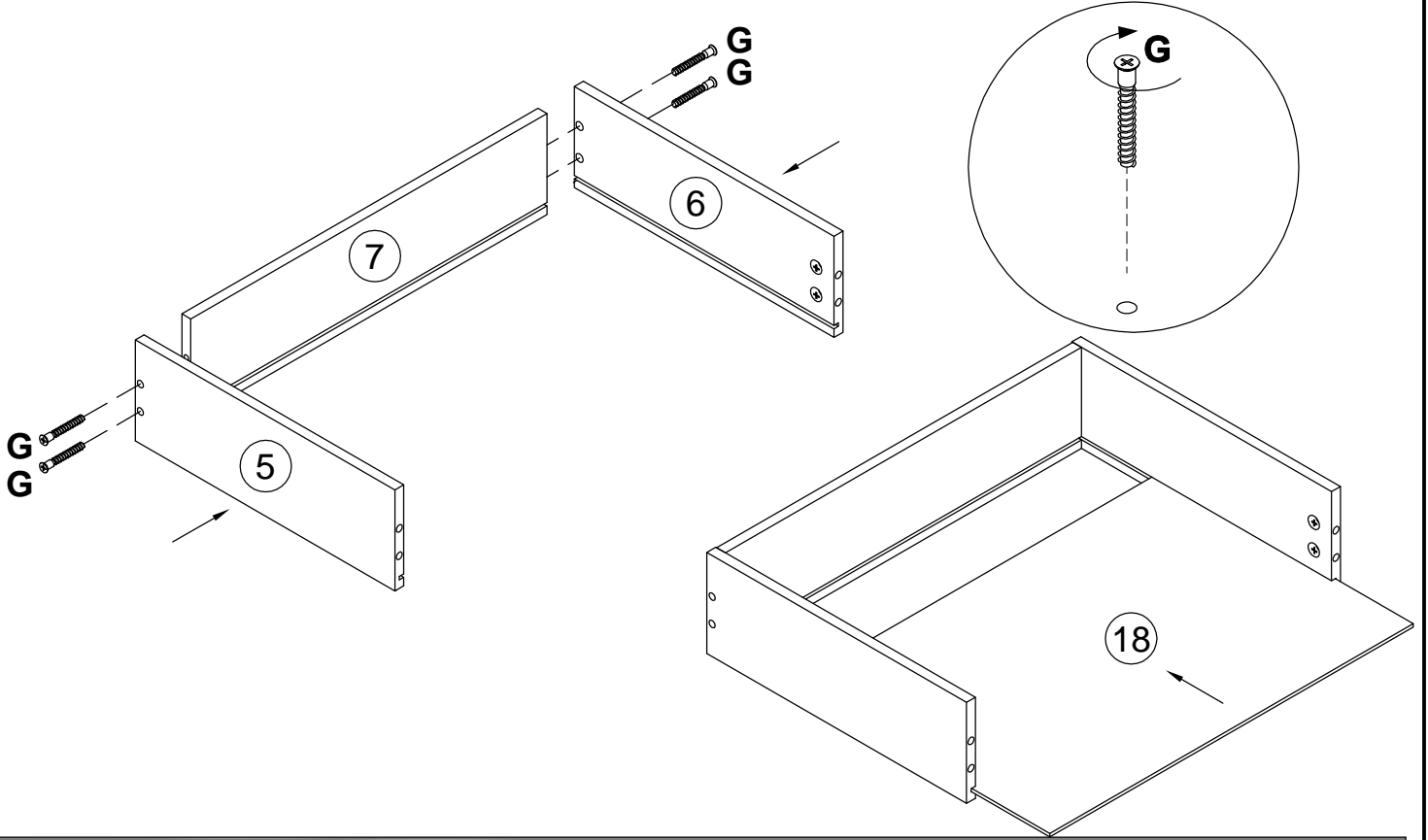

21  
x2

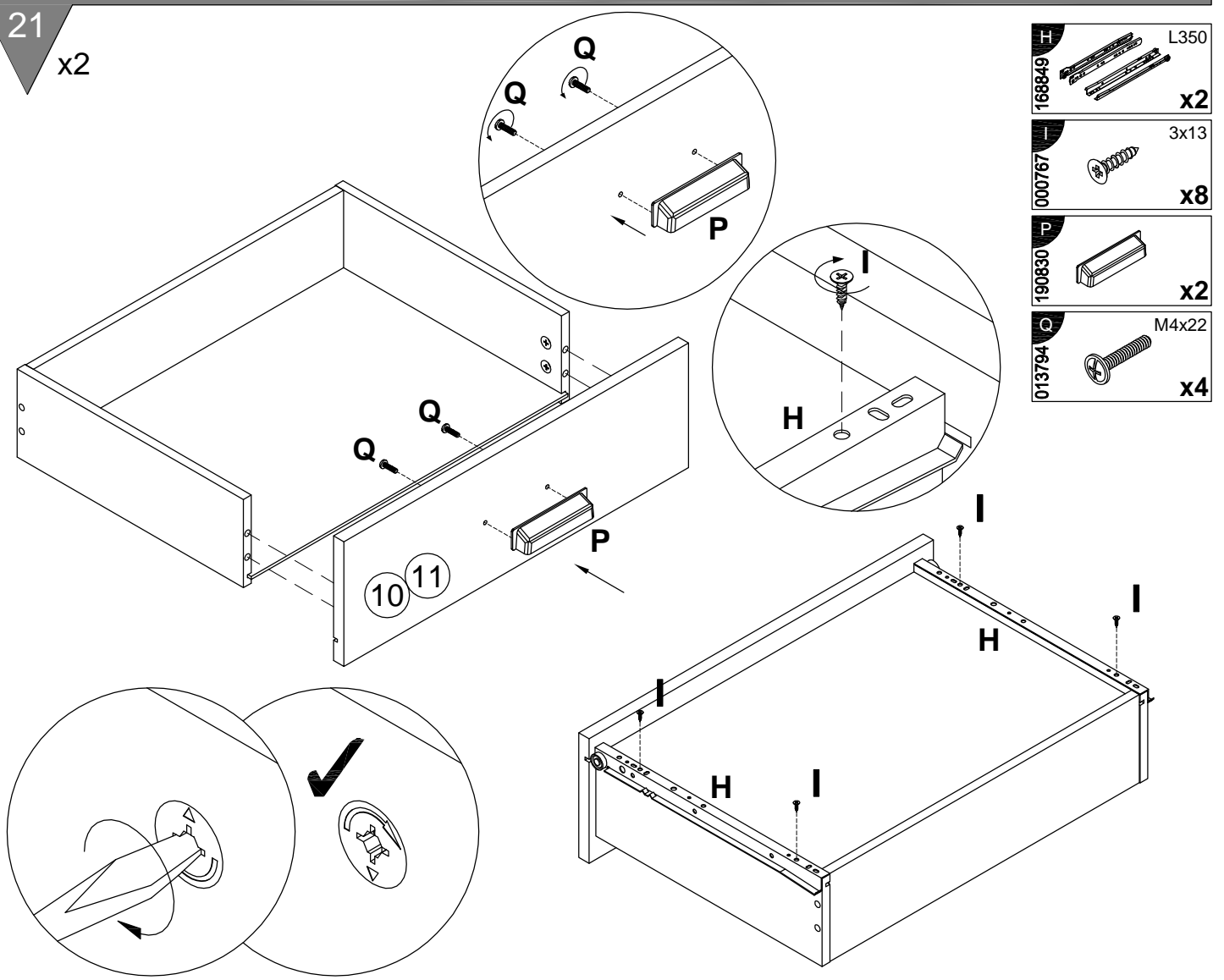

- |          |  |       |
|----------|--|-------|
| <b>H</b> |  | L350  |
| 168849   |  | x2    |
| <b>I</b> |  | 3x13  |
| 000767   |  | x8    |
| <b>P</b> |  | x2    |
| 190830   |  | M4x22 |
| <b>Q</b> |  | x4    |
| 013794   |  |       |

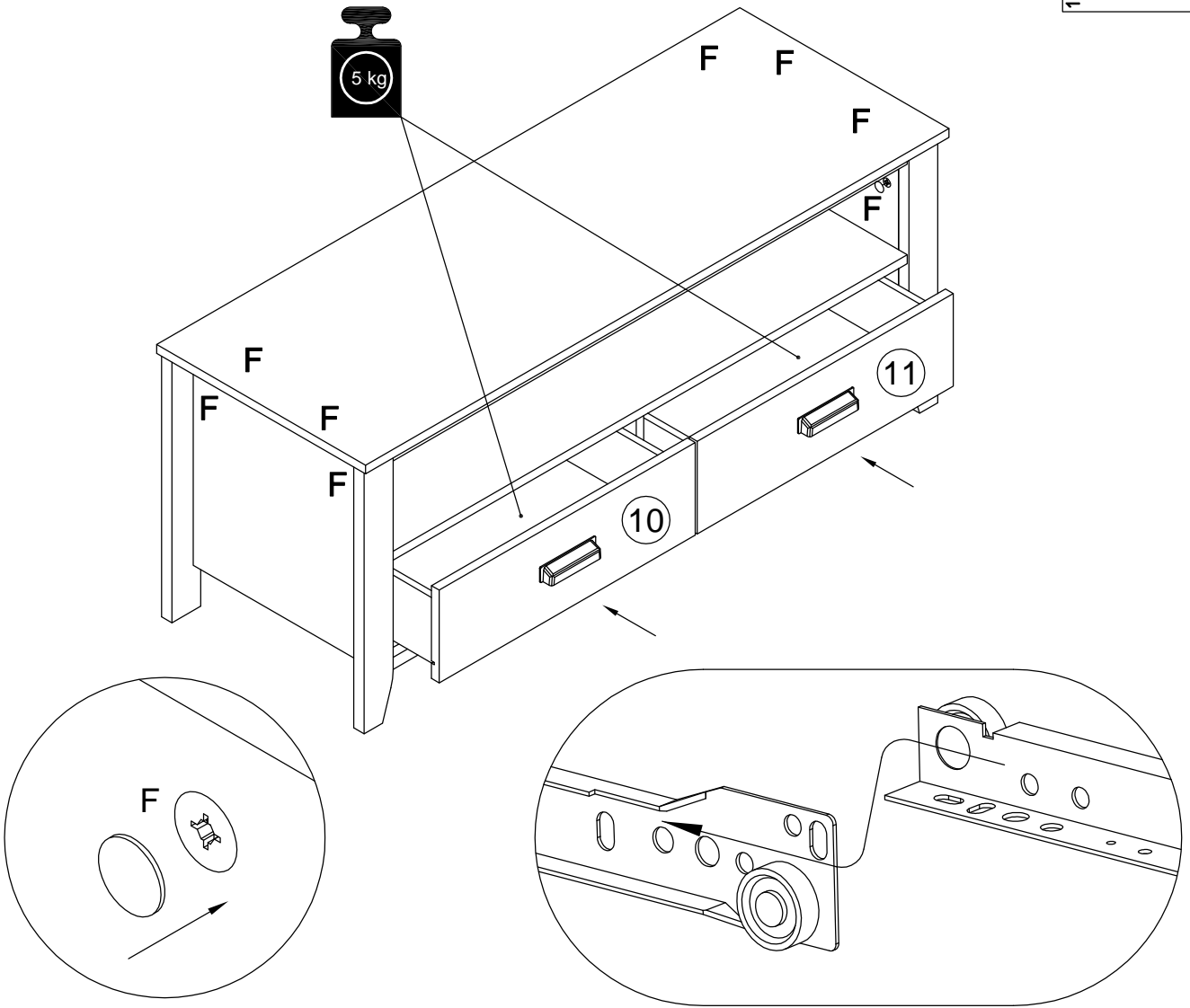

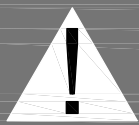

Achtung • Attention • Attenzione  
Opgelet • Uwaga • Pozor • Figyelem  
Atenție • Dikkat • Внимание

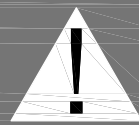

(D)	Wandbefestigung dient als Kippschutz – unbedingt anbringen! Bei einigen Wandtypen kann ein Spezialdübel erforderlich sein!
(GB)	The wall fastening serves to prevent tipping – be absolutely sure to mount it! For certain wall types, a special wall plug may be necessary!
(FR)	La fixation murale sert de protection contre le basculement – à installer impérativement ! Pour certains types de murs il faut des chevilles spéciales !
(IT)	Il fissaggio alla parete serve da protezione anti-ribaltamento – attaccarla assolutamente ! Per alcune strutture di parete può essere necessario un tassello speciale !
(NL)	Bevestiging aan de muur dient als kantelbescherming – zeker en vast bevestigen ! Bij enkele muurtypes is een speciale plug misschien vereist !
(PL)	Mocowanie do ściany jest jednocześnie zabezpieczeniem przed przewróceniem – koniecznie zamontować! Do niektórych rodzajów ścian koniecznie zastosować specjalne kołki mocujące.
(CZ)	Montáž na stěnu slouží jako ochrana proti převrhnutí – bezpodmienečně umístěte! Uněkterých typů stěn může být zapotřebí speciální hmoždinka !
(SK)	Upevnenie na stenu slúži ako ochrana proti prevráteniu – bezpodmienečne použite! Pre niektoré druhy stien môže byť potrebná špeciálna hmoždenka !
(HU)	A terméket a falhoz kel rögzíteni, különben az felborulhat! Egyes faltípusoknál speciális tiplit kell használni !
(RO)	Sistemul de fixare la perete serve ște ca protecție la răsturnare – de montat obligatoriu! Pentru unele tipuri de pereți este posibil să fie necesar un diblu special !
(TR)	Duvardaki sabitleme, devrilmeye karşı bir emniyet tedbiridir ve mutlaka monte edilmelidir! Bazı duvar tiplerinde bunun için özel bir dübel gereklidir !
(RU)	Обязательно установите крепление на стене во избежание опрокидывания ! Для некоторых типов стен может потребоваться специальный дюбель !